

- 75W5-1 1/B NOSE SKIN
- 75W5-2 0/B NOSE SKIN
- 75W5-3 1/B TOP SKIN
- 75W5-4 0/B TOP SKIN
- 75W5-5 WING ROOT TOP SKIN
- 75W6-1 1/B BOTTOM SKIN
- 75W6-2 0/B BOTTOM SKIN
- 75W6-3 1/B TRAILING EDGE SKIN
- 75W6-4 0/B TRAILING EDGE SKIN
- 75W6-5 WING ROOT ANGLE
- 75W6-6 FUEL ACCESS COVER
- 75W6-8 WING TIP

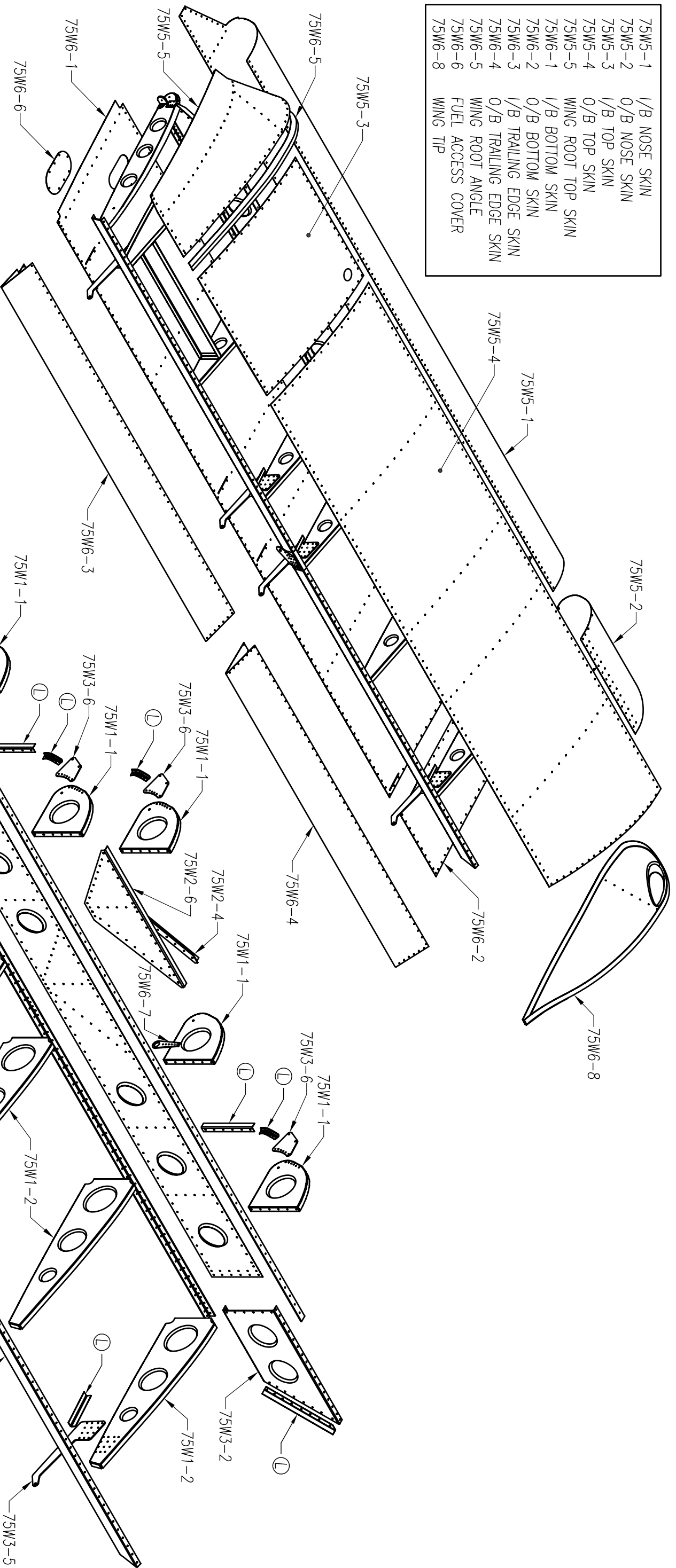

- 75W1-1 WING NOSE RIB
- 75W1-2 WING REAR RIB
- 75W1-2K WING TANK REAR RIB
- 75W2-1 WING SPAR WEB
- 75W2-2 UPPER SPAR CAP
- 75W2-3 LOWER SPAR CAP
- 75W2-4 STRUT ANGLE
- 75W2-5 FRONT UPPER FITTING
- 75W2-6 SPAR WEB DOUBLER
- 75W2-7 SPAR ROOT FITTING
- 75W3-1 SPAR ROOT DOUBLER
- 75W3-2 SPAR TIP
- 75W3-3 REAR UPPER STRUT FITTING
- 75W3-4 REAR ROOT DOUBLER
- 75W3-5 FLAPERON ARM
- 75W3-6 SLAT SUPPORT

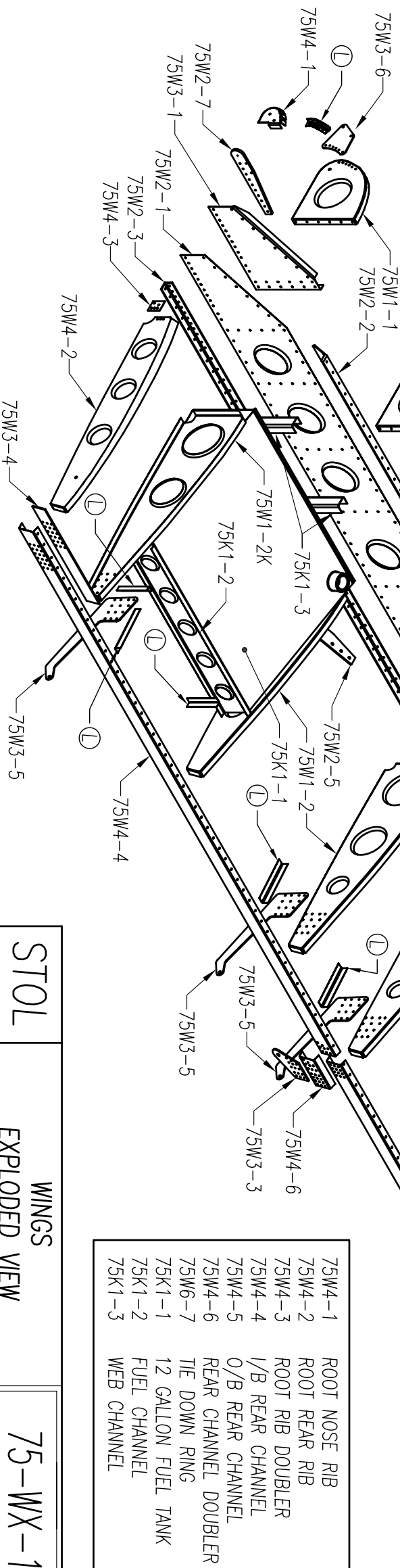

- 75W4-1 ROOT NOSE RIB
- 75W4-2 ROOT REAR RIB
- 75W4-3 ROOT RIB DOUBLER
- 75W4-4 1/B REAR CHANNEL
- 75W4-5 0/B REAR CHANNEL
- 75W4-6 REAR CHANNEL DOUBLER
- 75W6-7 TIE DOWN RING
- 75K1-1 12 GALLON FUEL TANK
- 75K1-2 FUEL CHANNEL
- 75K1-3 WEB CHANNEL

STOL
CH 750

WINGS
EXPLODED VIEW

75-WX-1