

FLAP CONTROL ASSEMBLY

AILERONS BELLCRANKS

ELEVATOR & STICK ASSEMBLY

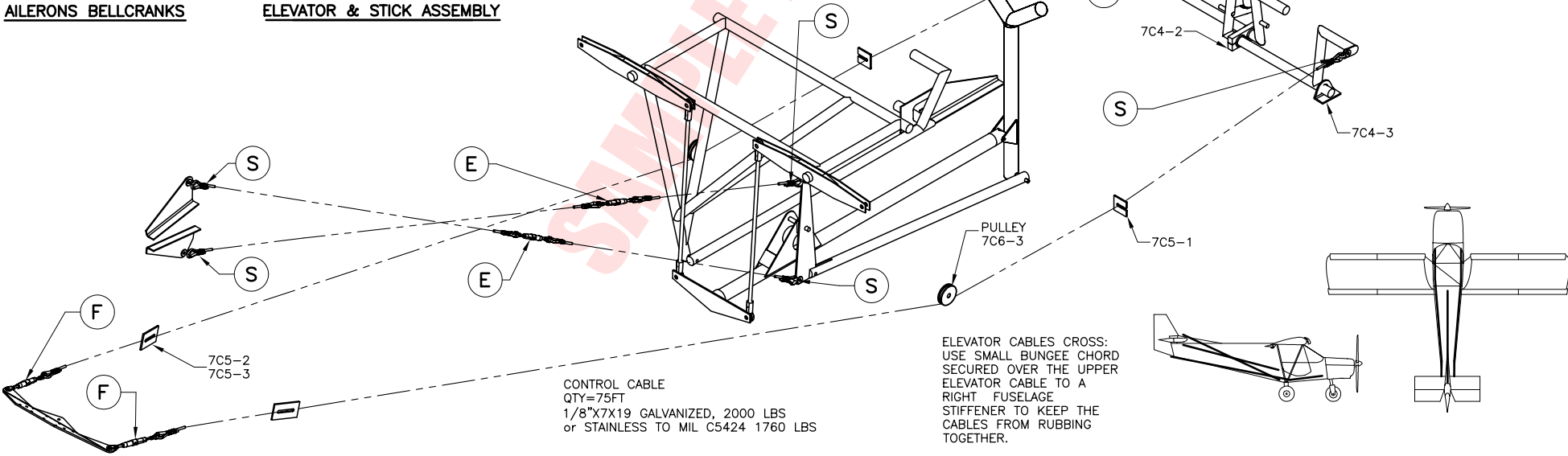

CONTROL CABLE
 QTY=75FT
 1/8"X7X19 GALVANIZED, 2000 LBS
 or STAINLESS TO MIL C5424 1760 LBS

ELEVATOR CABLES CROSS:
 USE SMALL BUNGEE CHORD
 SECURED OVER THE UPPER
 ELEVATOR CABLE TO A
 RIGHT FUSELAGE
 STIFFENER TO KEEP THE
 CABLES FROM RUBBING
 TOGETHER.

DETAIL E



ASSEMBLY AN140: BARREL TURNBUCKLE AN155-22S
 CABLE EYE END AN170-22RS, CABLE EYE LEFT AN170-22LS QTY=2



1/8" CABLE THIMBLE
 (AN100-4)
 F-15-204 QTY=12

DETAIL F

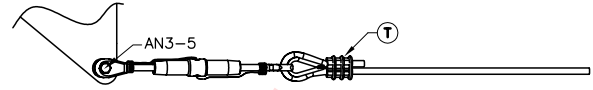

ASSEMBLY AN130: BARREL TURNBUCKLE AN155-22S, AN161-22RS
 FORK LEFT AN170-22LS, CABLE EYE RIGHT AN161-22RS QTY=2
 AN3-5 BOLT WASHER AN960-10 CASTLE NUT AN310-3 COTTER PIN AN 380-2-2



CABLE SHACKLES
 AN115-21
 QTY=6

DETAIL S

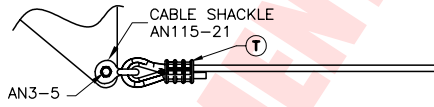

CABLE SHACKLE AN115-21 WITH AN3-5 BOLT WASHER AN960-10,
 CASTLE NUT AN310-3 COTTER PIN AN 380-2-2

DETAIL S
 CABLE SHACKLE TO
 RUDDER PEDALS

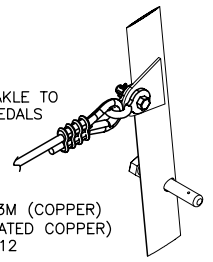

DETAIL T

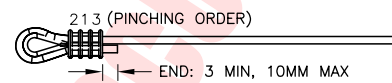

1/8" CABLE THIMBLE, NICOPRESS SLEEVE

NICOPRESS: 18-3M (COPPER)
 24-3M (ZINC PLATED COPPER)
 S-11-004 QTY=12
 USE NICOPRESS
 SWAGING TOOL